



NOTICE

Systeme de Montage

Octobre 2022



www.extha.com

Tél : 01 41 58 10 34

Adresse : 3 rue magnier BEDU LOT
C3 95410 GROSLAY

SOMMAIRE

Boîte à outils.....	Page 2
Préparation des mélanges.....	Page 3
Présentation et choix des plaques.....	Page 4 à 5
Système horizontal.....	Page 6 à 12
Système vertical.....	Page 13
Pose d'une manchette.....	Page 14 à 15
Pose d'un volet tunnel.....	Page 16
Pose de protections de plats carbone.....	Page 17
Pose d'un platelage.....	Page 18 à 20
Pose d'un joint de dilatation.....	Page 21
Pose d'un piège à son.....	Page 22



BOÎTE À OUTILS



CUTTER



SCIE



PLATOIR



NIVEAU



COUTEAU À ENDUIRE



MASSETTE



HACHETTE



MÈTRE



MÉLANGEUR



OUTIL DE POSE
DE CHEVILLE



PLATEFORME
INDIVIDUELLE
ROULANTE

LES ÉQUIPEMENTS DE PROTECTION INDIVIDUEL



LES OUTILS ÉLECTROPORTATIFS



ENROULEUR



MEULEUSE



PERFORATEUR



PRÉPARATIONS DES MÉLANGES

COLLE EXTHAFIX



Ajouter de la colle jusqu'à saturation dans l'eau. Laisser la colle s'hydrater pendant quelques minutes et utiliser le malaxeur pour obtenir une pâte homogène et onctueuse.



EXEMPLES DE TAUX DE GÂCHAGE

EAU	Poudre EXTHAFIX
1 litre	1,5 kg
5 litres	7,5 kg
10 litres	15 kg
17 litres	1 sac (25 kg)



PRÉSENTATION DES PLAQUES

PLAQUE STANDARD

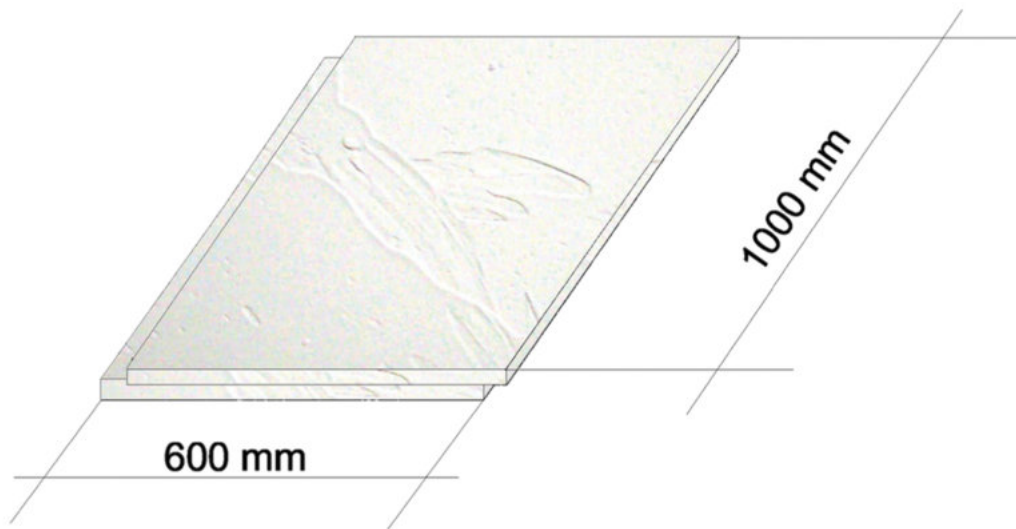

PLAQUE NORMALE

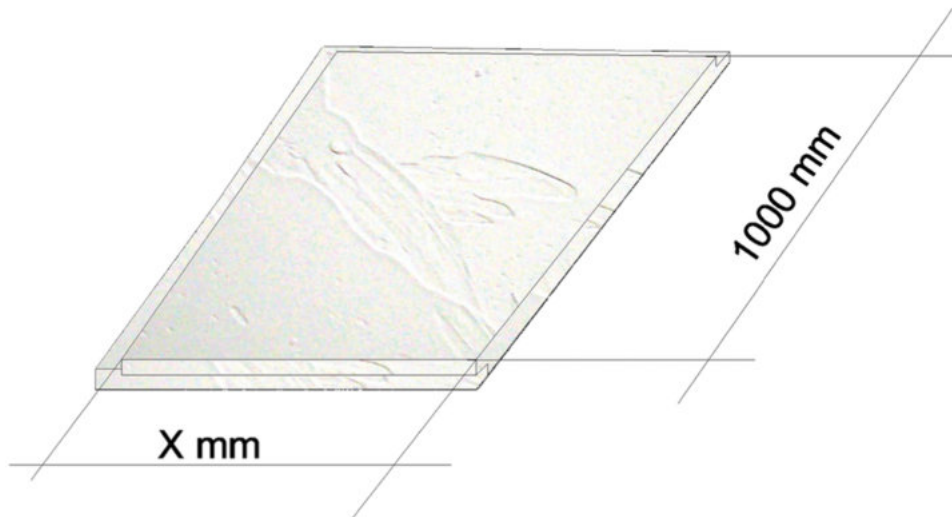

Les plaques normales présentent toutes une longueur de 1000 mm et leur largeur utile X se décline de 200 mm jusque 750 mm par pas de 50 mm. Elles possèdent des feuilures sur trois de leurs côtés.



CHOIX DES PLAQUES

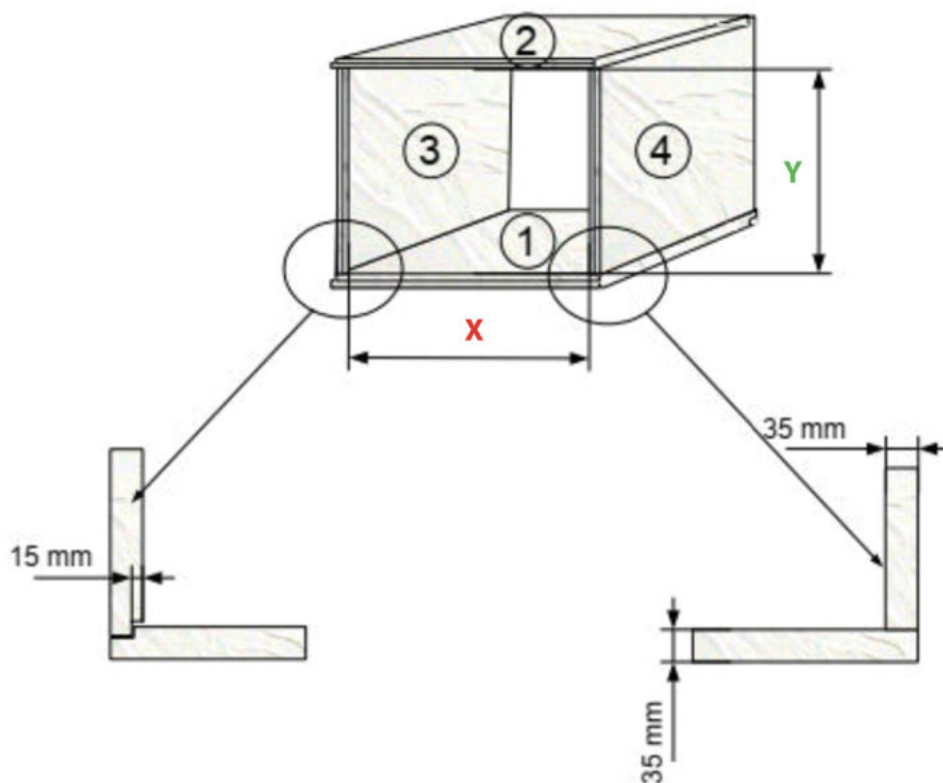

X représente la largeur intérieure du conduit.

Y représente la hauteur intérieure du conduit.

Il faut utiliser des plaques comme suit :

- (1) et (2) dimension $X + 50$ mm
- (3) et (4) dimension Y



POSE DES CONDUITS HORIZONTALS

ÉTAPE 1 :

POSITIONNEMENT DES TIGES FILETÉES SOUS LA DALLE DE BÉTON

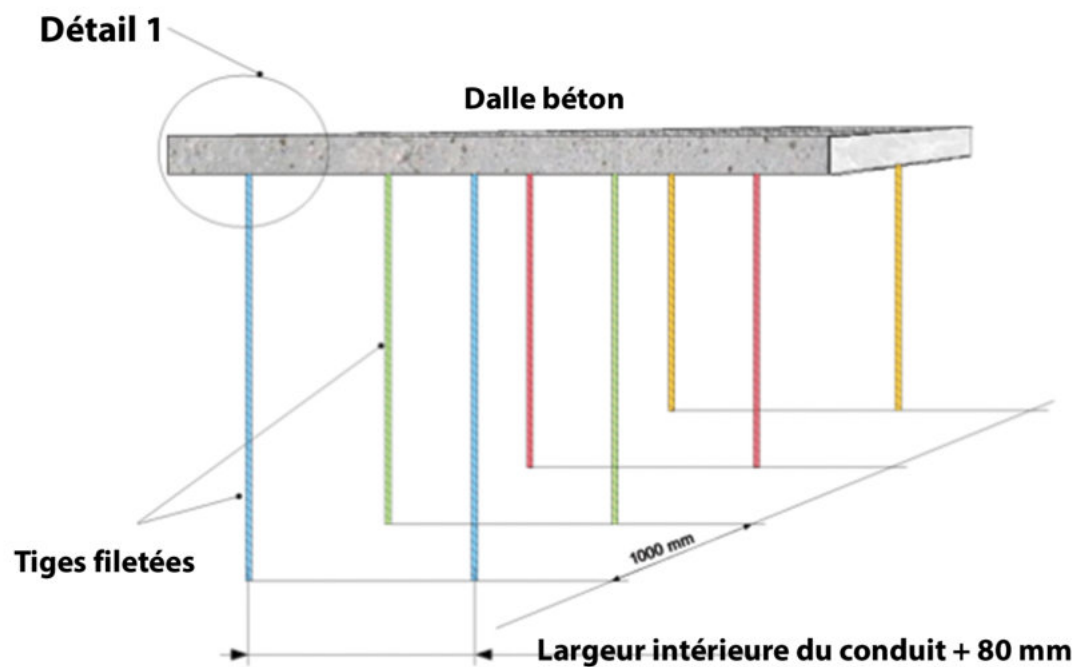

Chaque paire de tiges filetées est positionnée tous les mètres.
L'espacement entre deux tiges est : largeur intérieure du conduit + 80 mm.

Détail 1

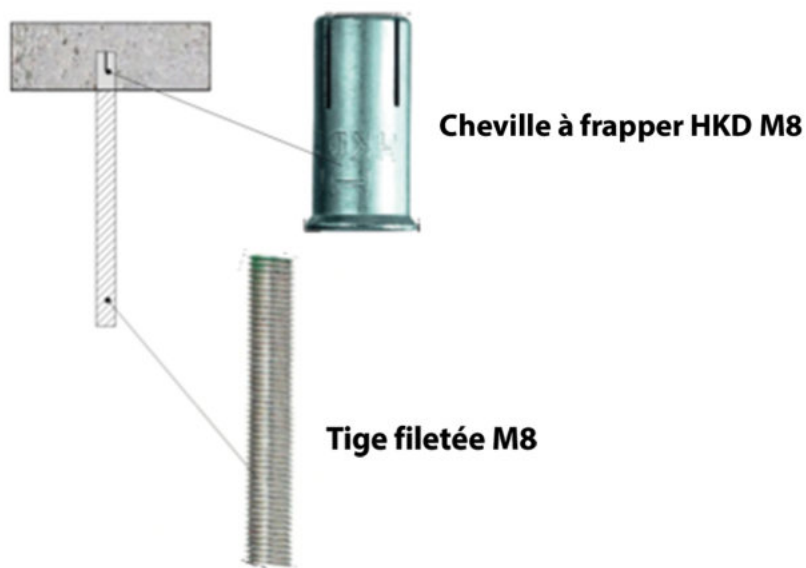

POSE DES CONDUITS HORIZONTALS

ÉTAPE 2 :

POSE DES SUPPORTS

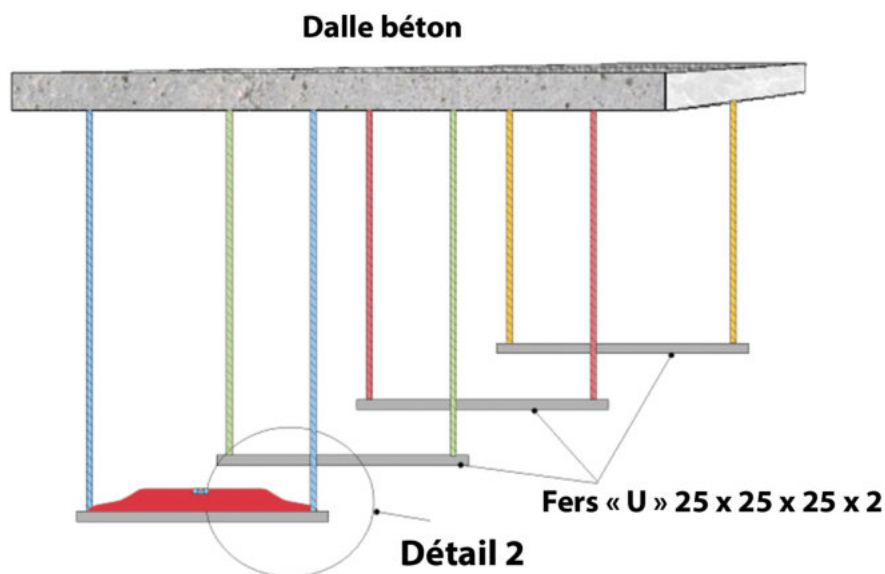

Mise à niveau des supports et réglage de la hauteur en fonction de l'implantation du conduit.

Détail 2

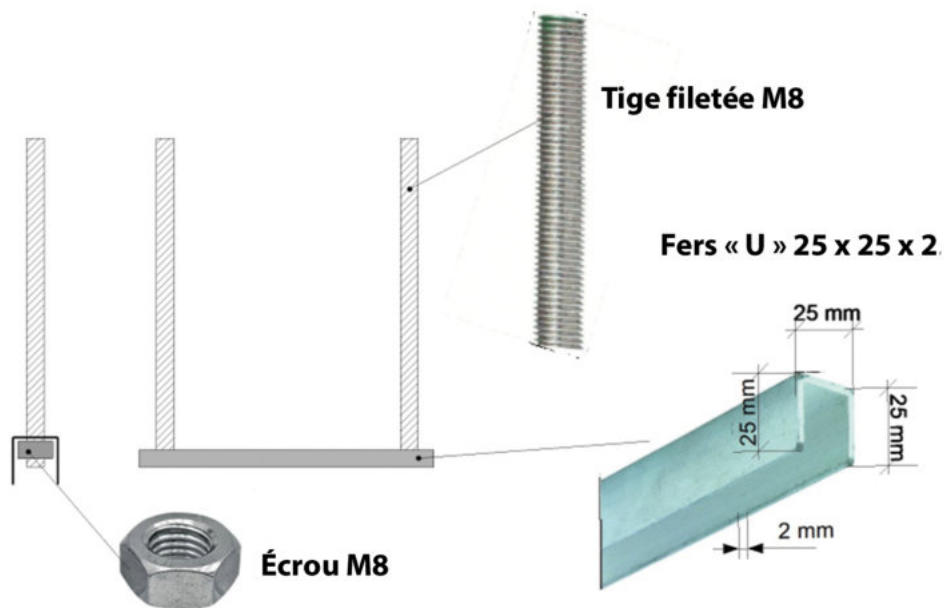

ÉTAPE 3 :

POSE DE LA PREMIÈRE PLAQUE

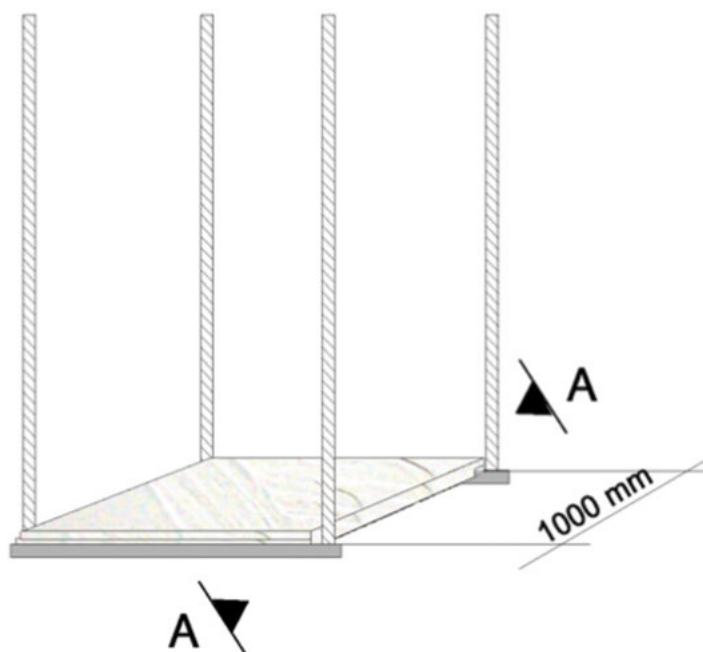

VUE EN COUPE A - A

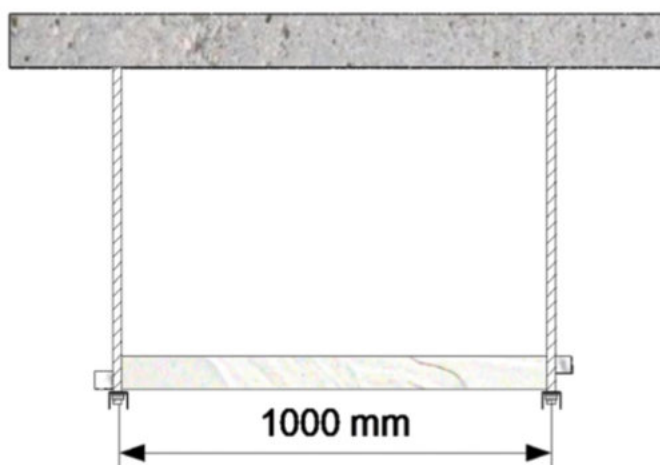

ÉTAPE 4 :

POSE DES PLAQUES LATÉRALES

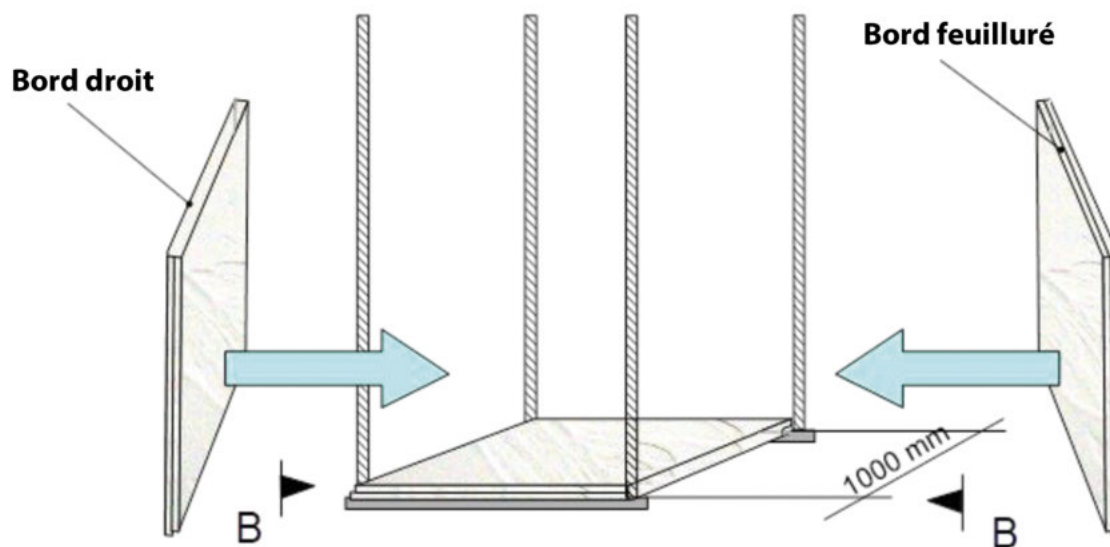

VUE EN COUPE B - B

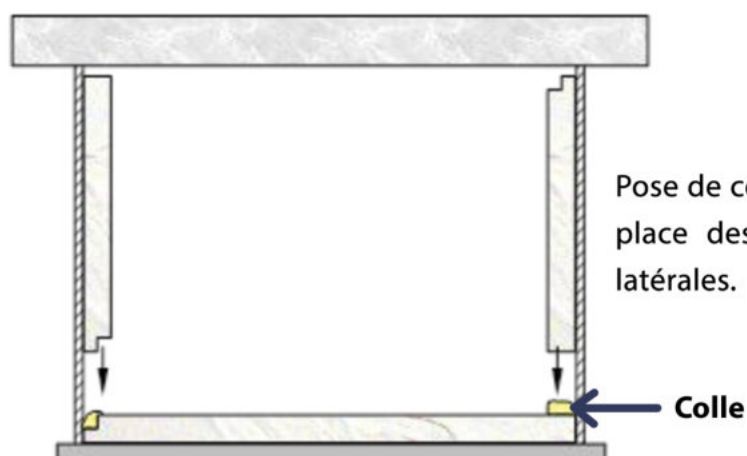

Pose de colle EXTHAFIX puis mise en place des plaques sur les 2 faces latérales.



ÉTAPE 5 :

SCELLEMENT DES PLAQUES LATÉRALES

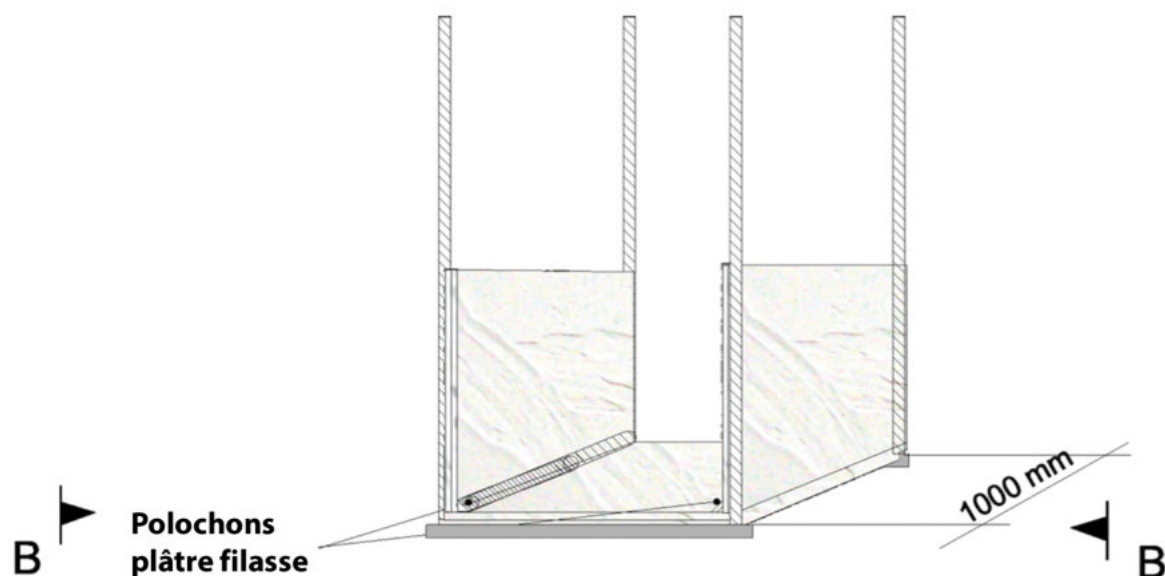

VUE EN COUPE B - B

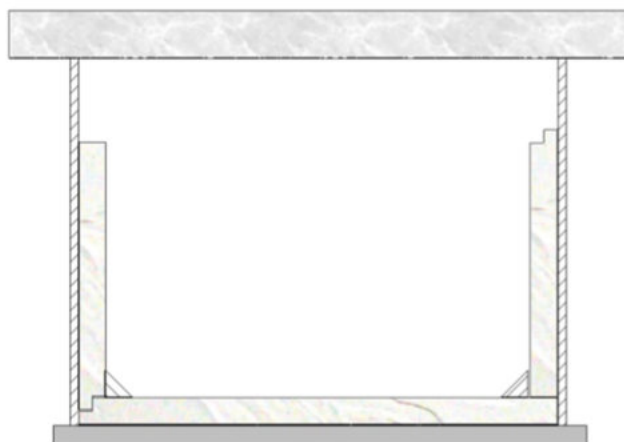

Pose de polochons réalisées par mélange de filasse et de plâtre pour sceller les plaques et parfaire l'étanchéité.



ÉTAPE 6 :

FERMETURE DU CAISSON

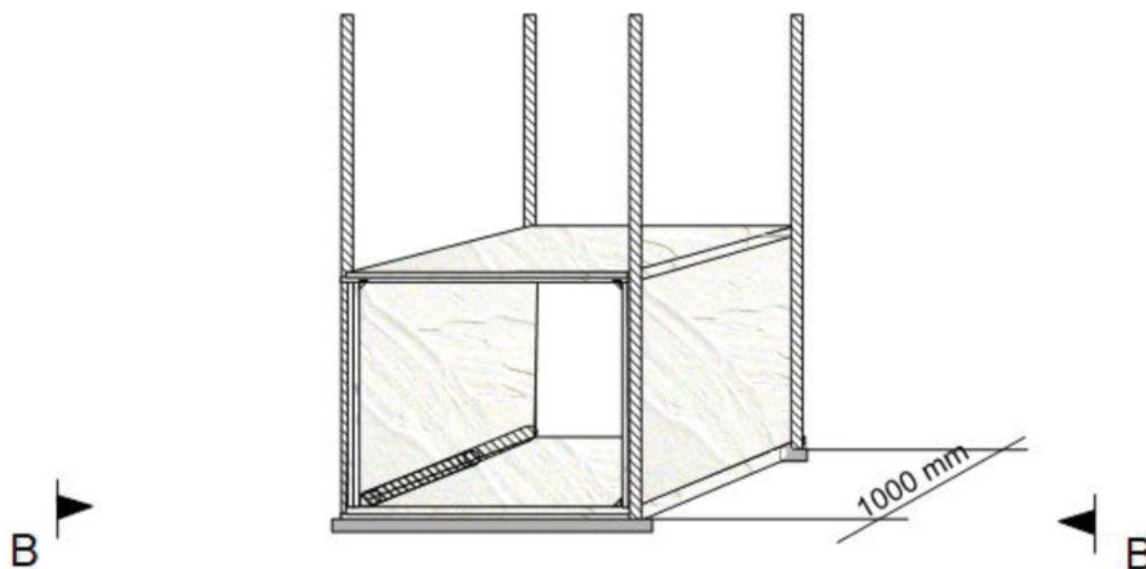

VUE EN COUPE B - B

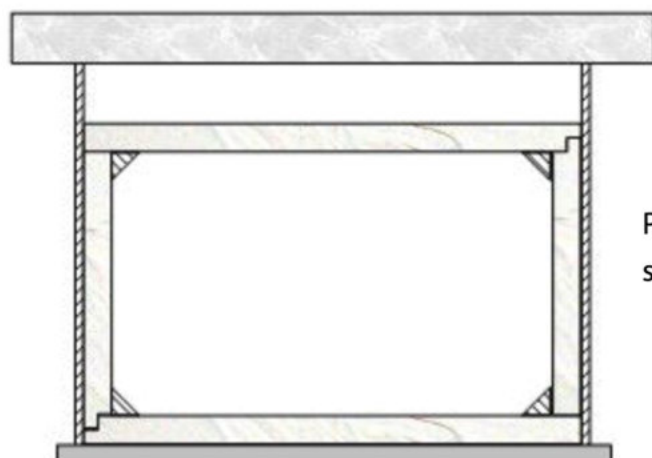

Pose de la dernière face après encollage et scellement de la plaque par polochonage



ÉTAPE 7 :

POSE DES COQUILLES

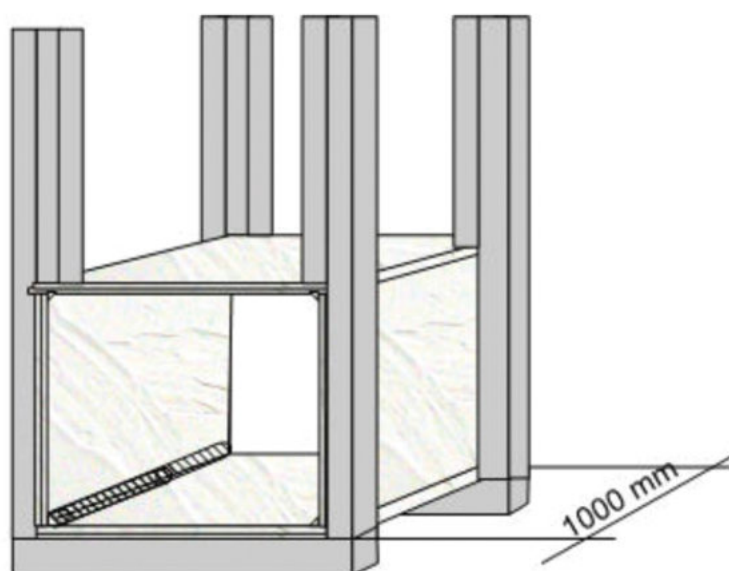

VUE EN COUPE B - B

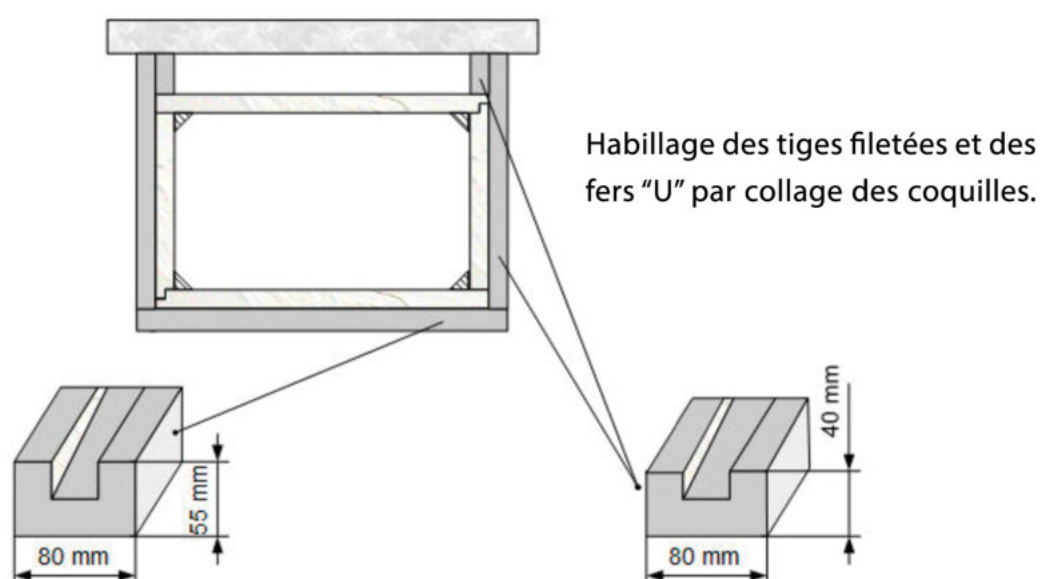

POSE DES CONDUITS VERTICAUX

COUPE A - A

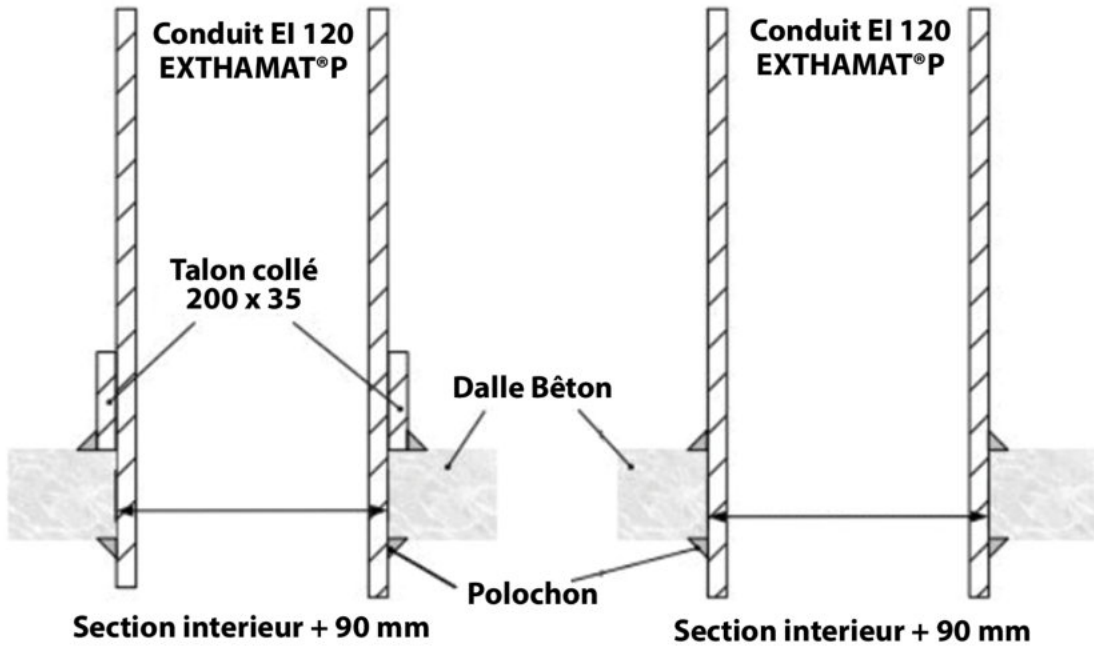

COUPE B - B

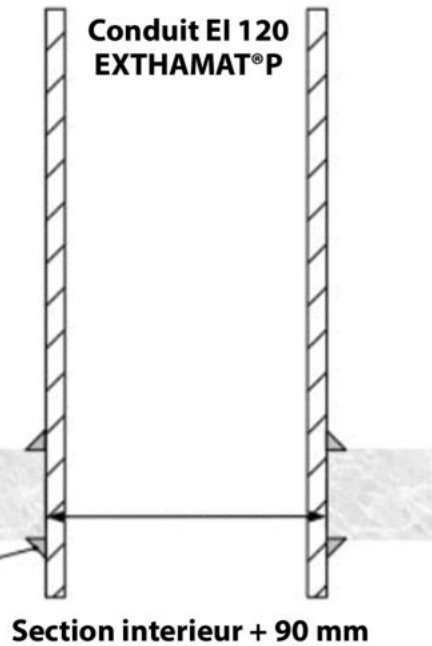

VUE EN PLAN

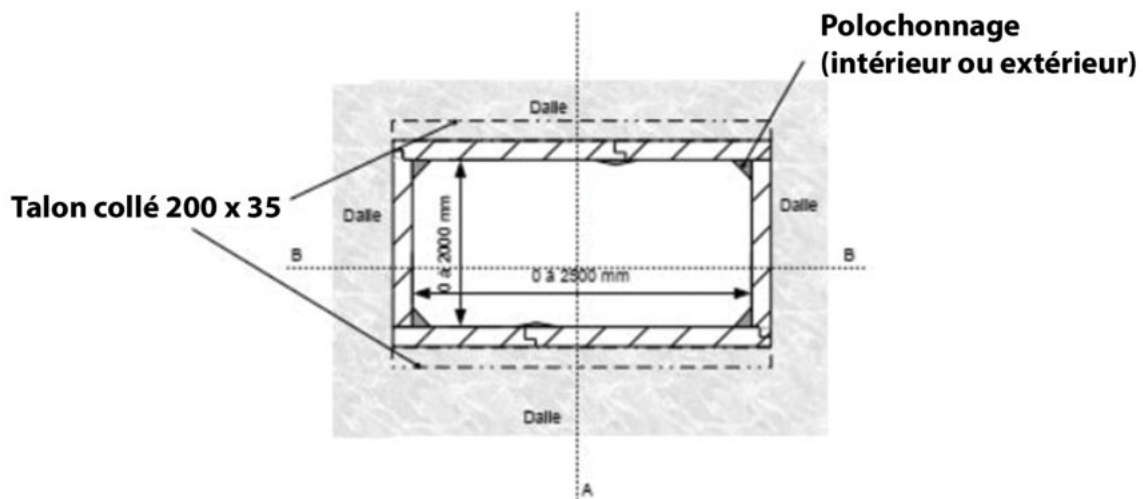

POSE D'UNE MANCHETTE

DISPOSITION DES VB ET VH SUR LA HAUTEUR DU CONDUIT

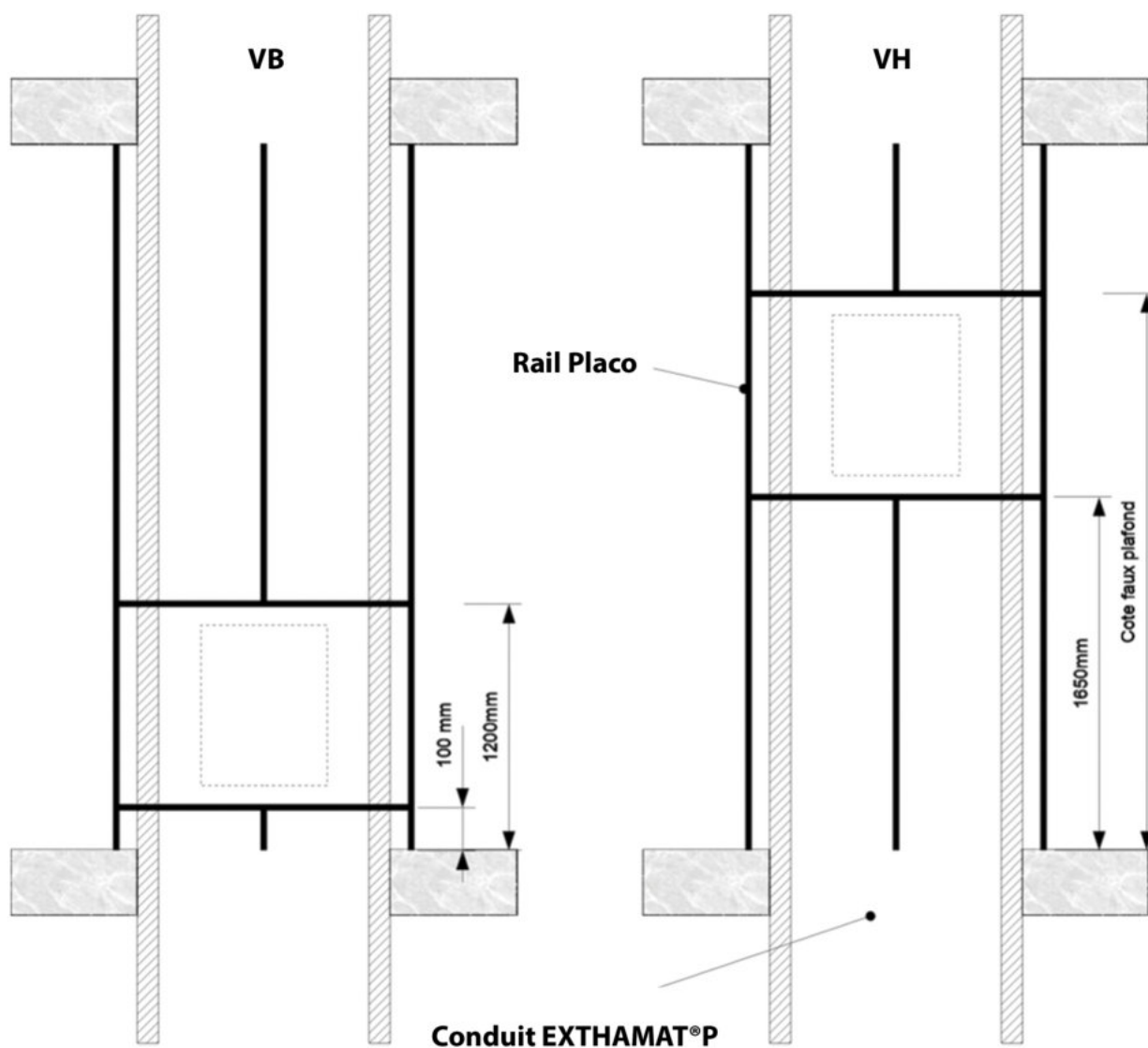

POSE D'UNE MANCHETTE

DISPOSITION DE LA MANCHETTE ET DU CONTRE-CADRE DU VOLET

VUE DE DESSUS

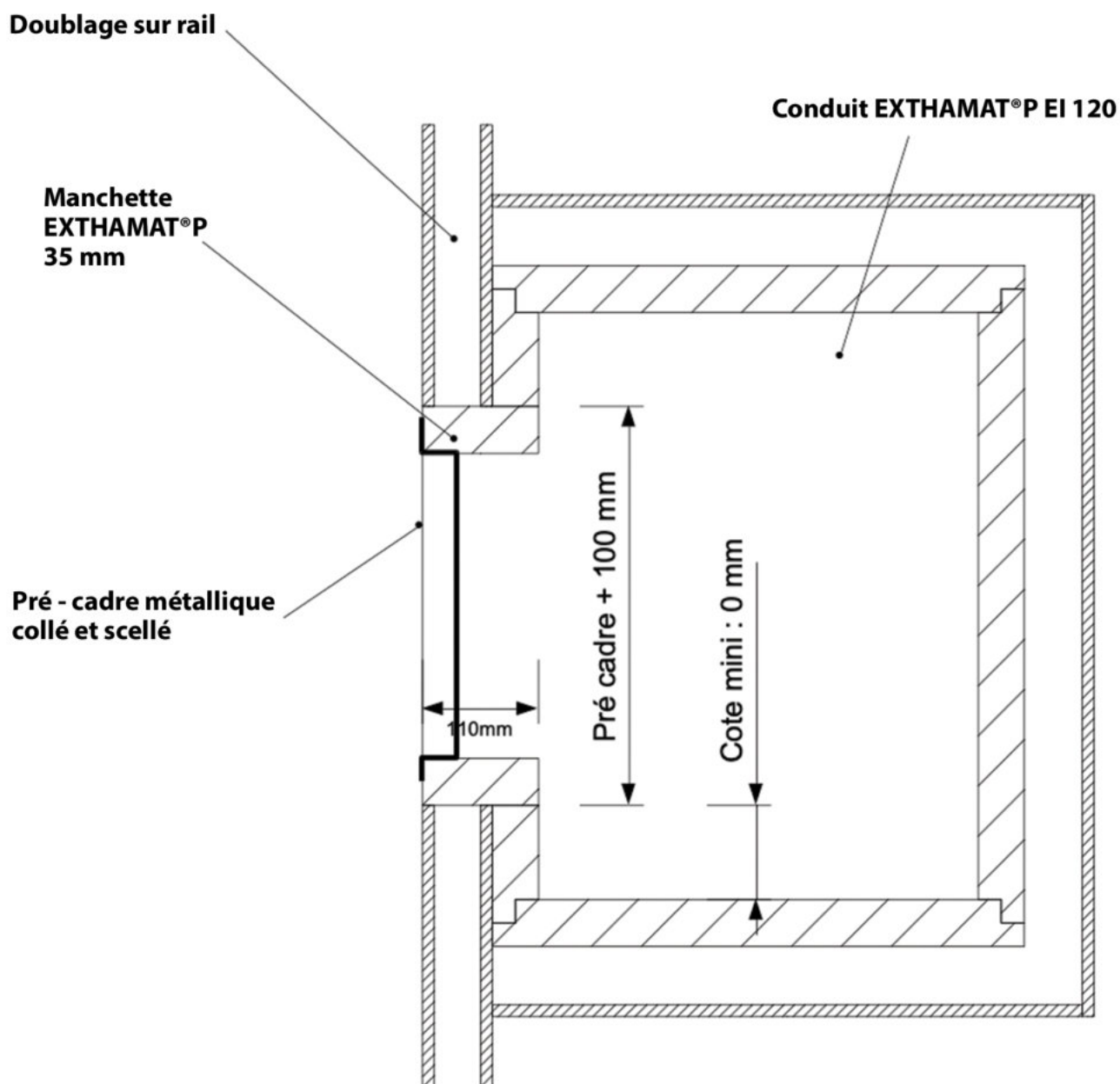

POSE D'UN VOLET TUNNEL

Conduit EXTHAMAT®P
EI120 // 35 mm



Coquille EXTHAMAT®P 80x80 mm

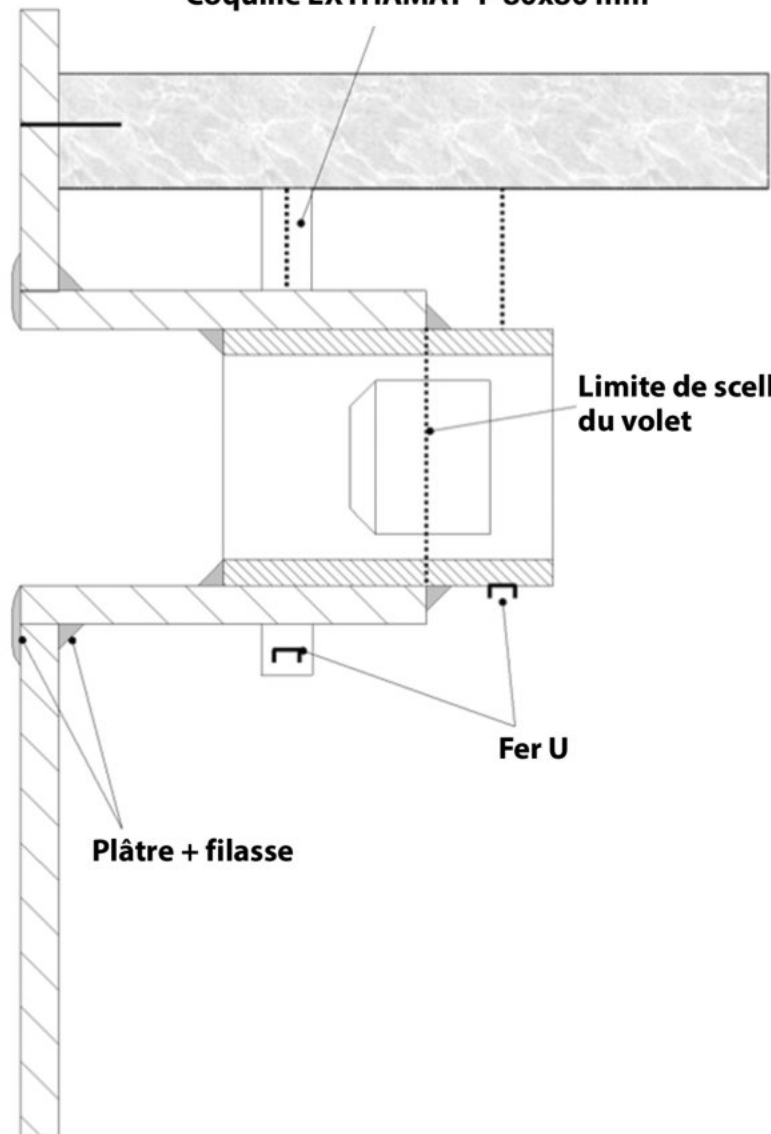

Limite de scellement
du volet

Fer U

Plâtre + filasse



POSE D'UNE PROTECTION DE PLATS DE CARBONE

VUE EN COUPE

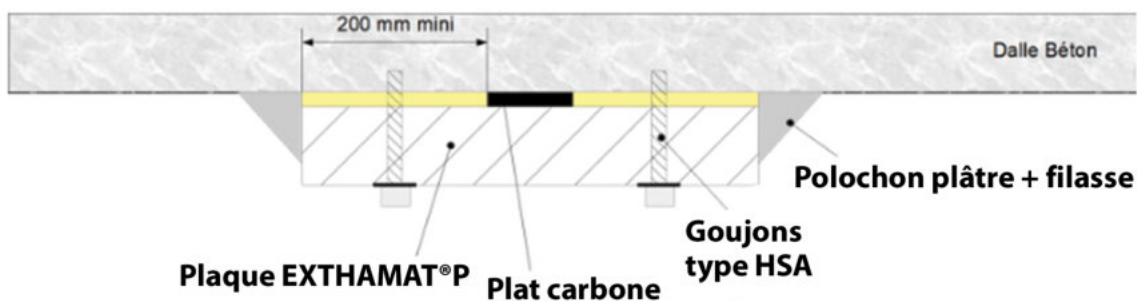

VUE SOUS LA PROTECTION

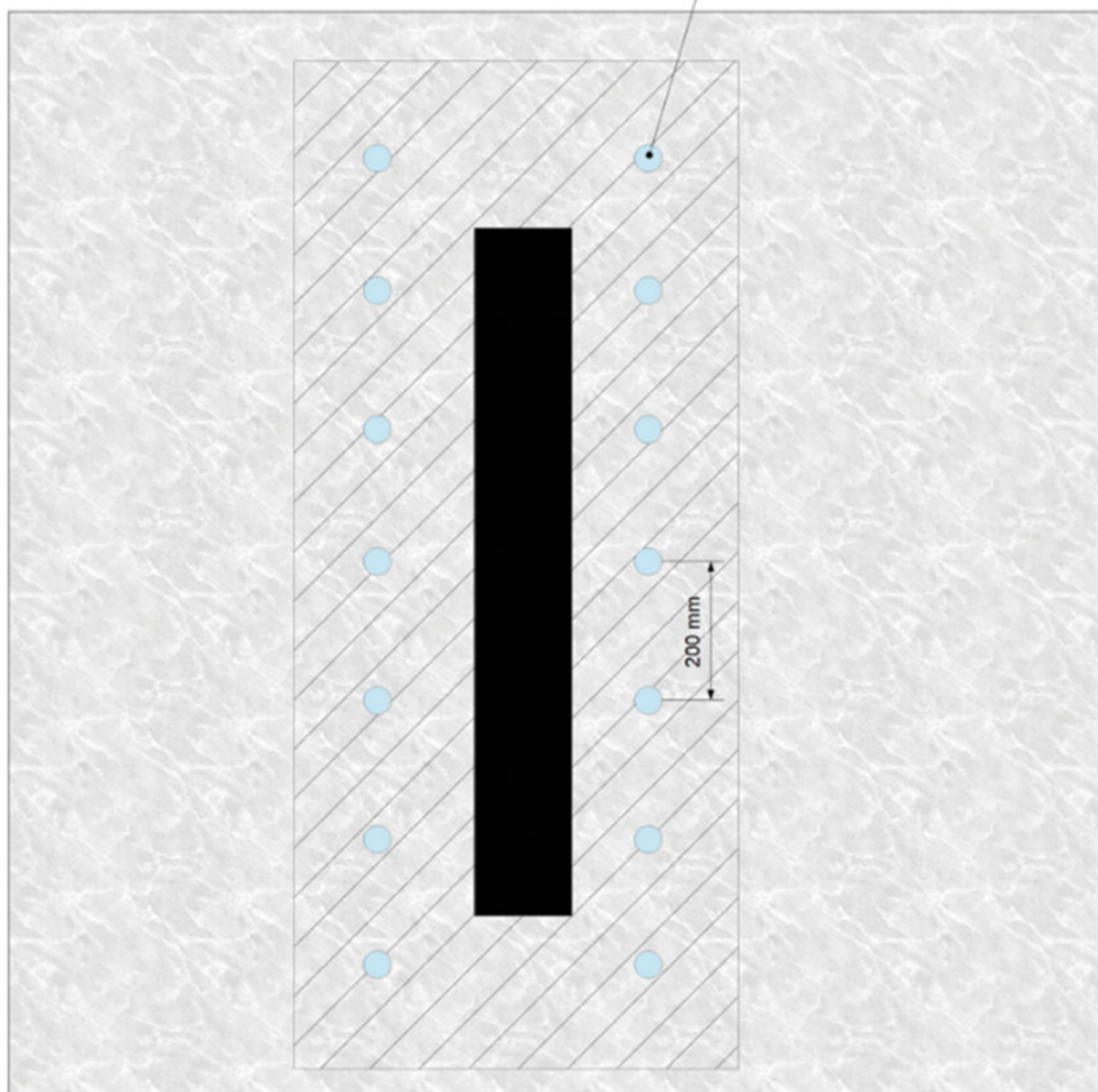

POSE D'UN PLATELAGE

ÉTAPE 1 :

NIVEAU N

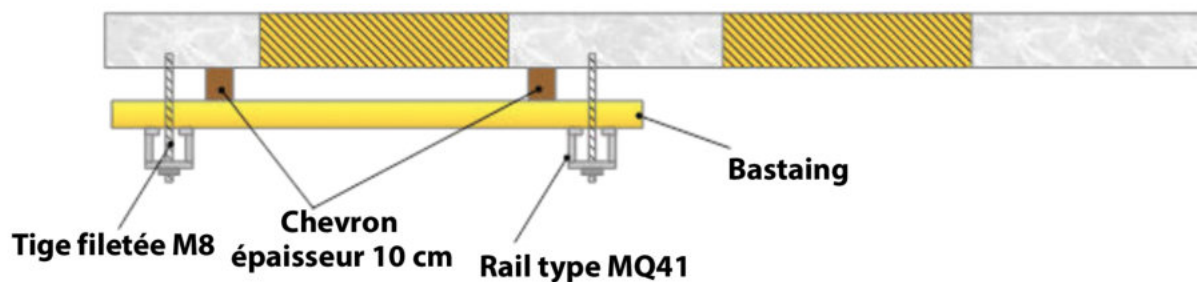

ÉTAPE 2 :

NIVEAU N - 1

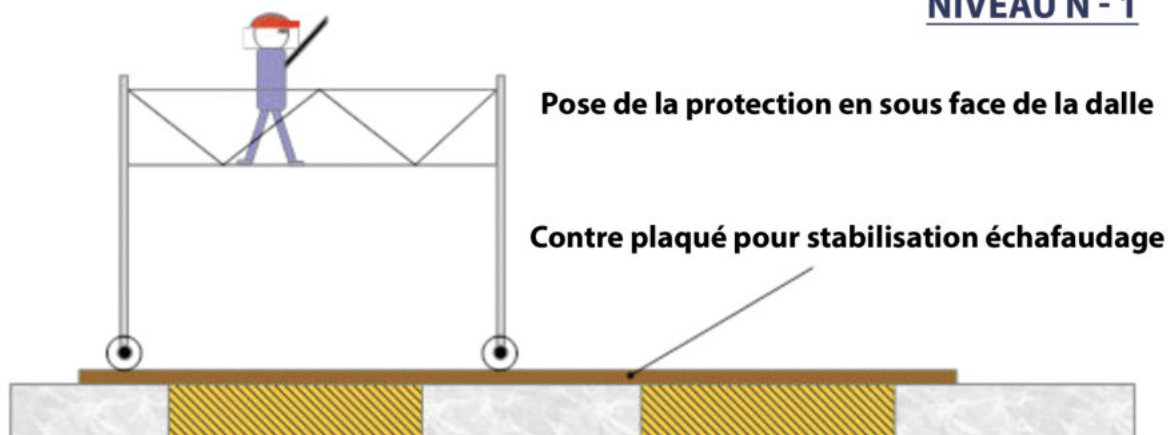

ÉTAPE 3 :

NIVEAU N

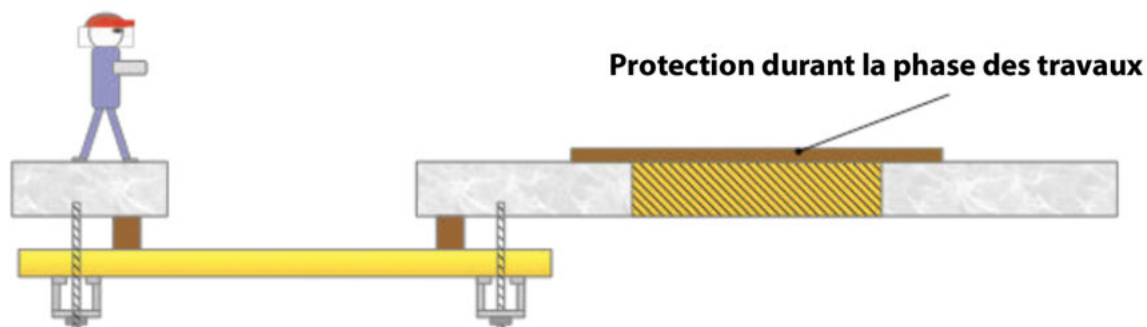

POSE D'UN PLATELAGE

ÉTAPE 4 :

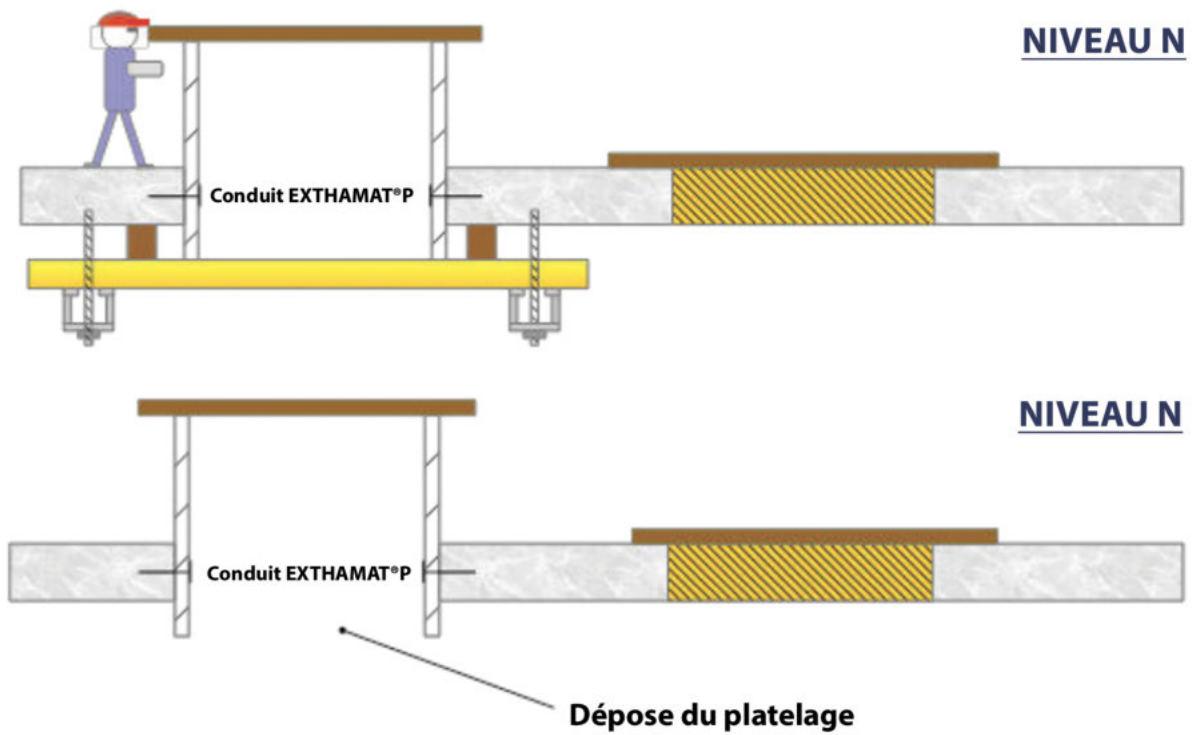

ÉTAPE 5 :

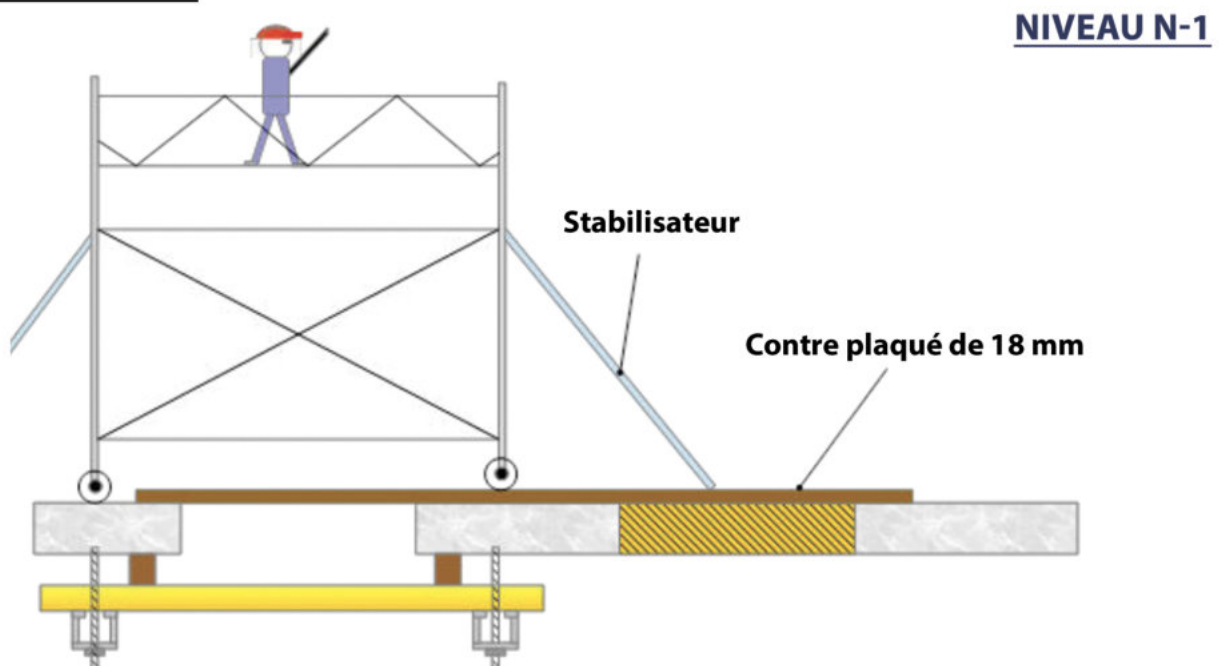

POSE D'UN PLATELAGE

ÉTAPE 6 :

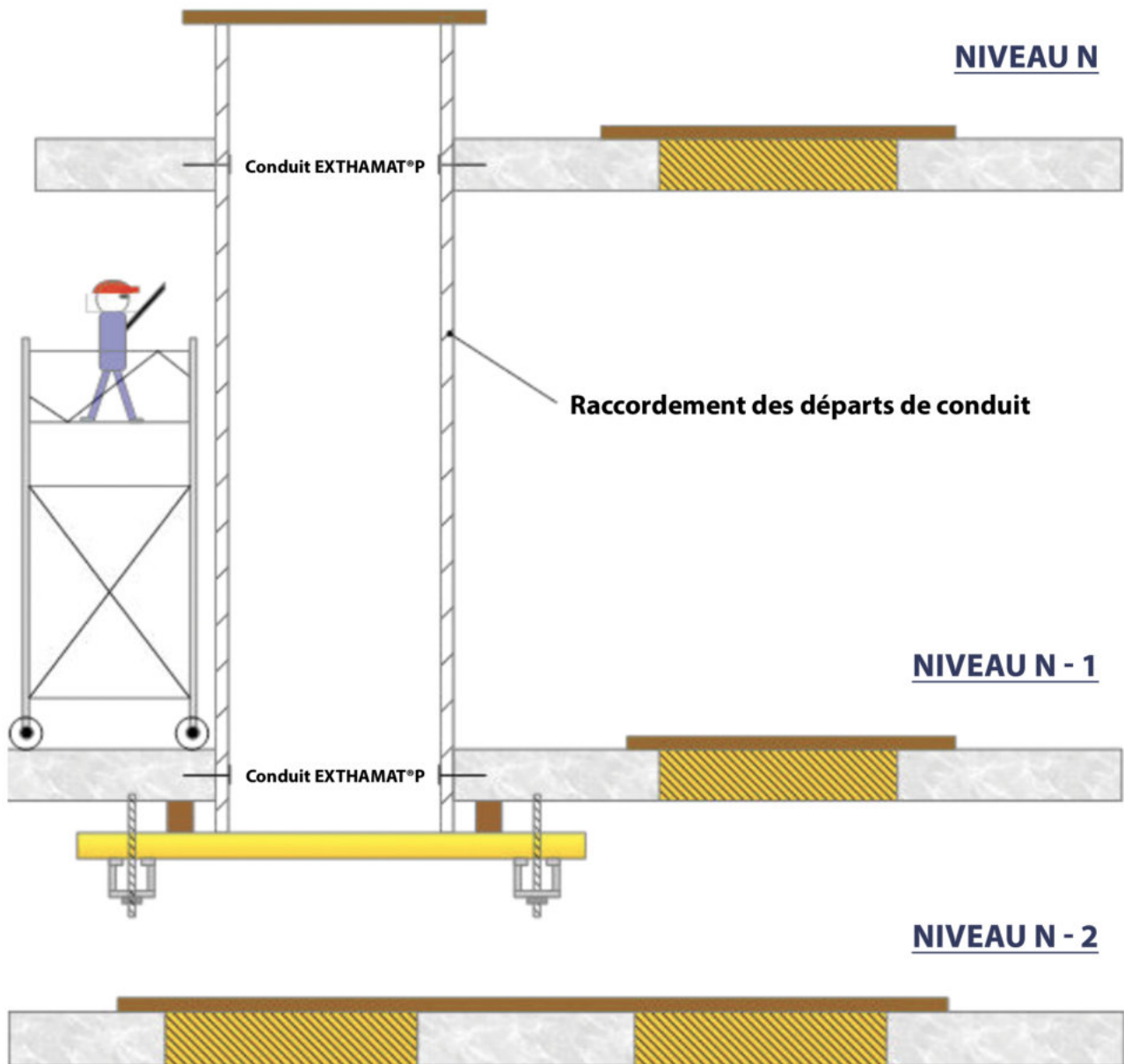

POSE D'UN JOINT DE DILATATION

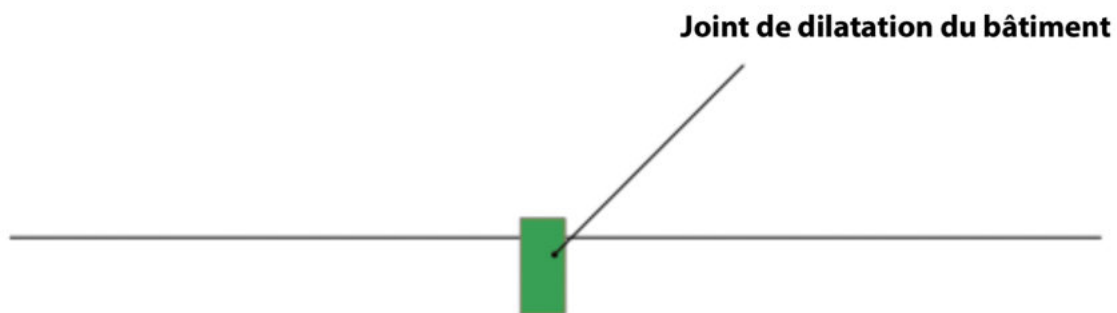
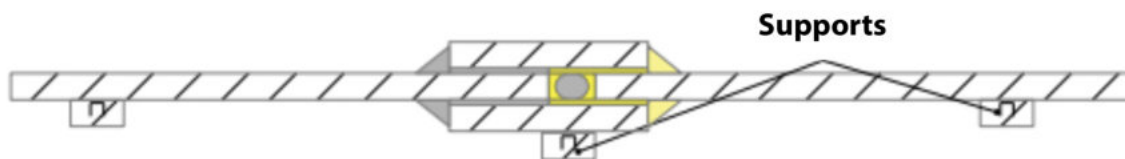
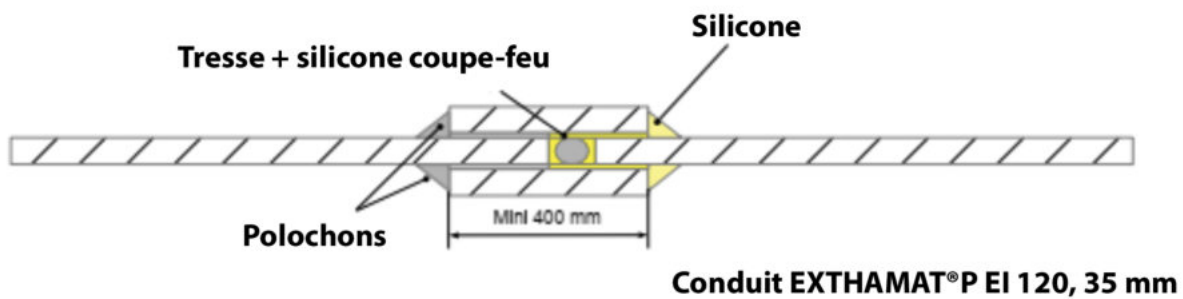

MONTAGE TYPE D'UN PIÈGE À SON

COUPE A - A

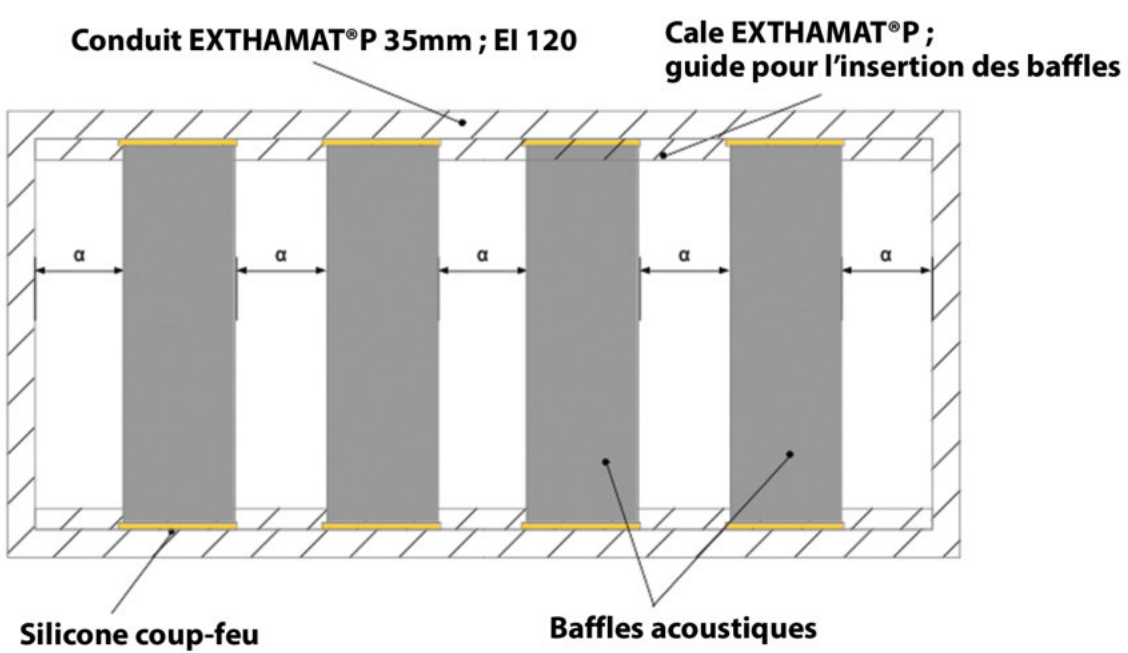

α = répartitions des baffles à égale distance

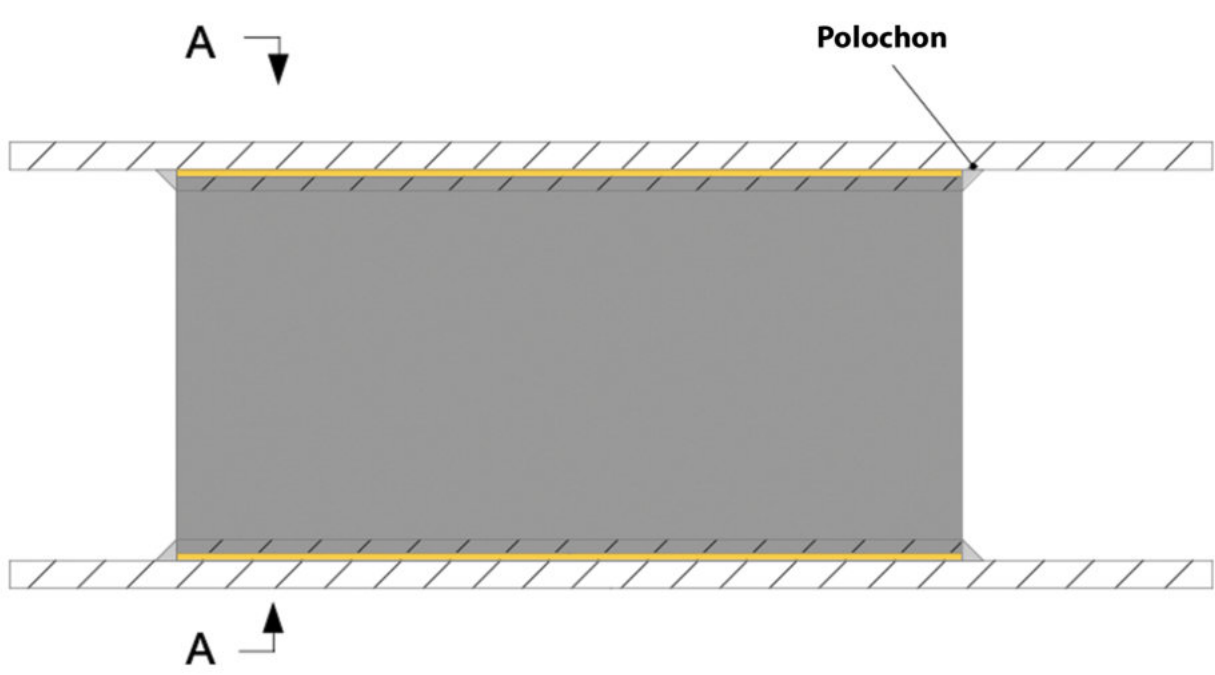



Tél : 01 41 58 10 34

Email : contact@extha.fr

Adresse : 3 rue magnier BEDU LOT C3 95410 GROSLAY

Site web : www.extha.com

